

## UL Recognized Filtered Terminal Blocks

### Application

Recognized by UL, the TUSONIX Filtered Terminal Block is specifically designed to save time and money for EMI filtering applications.

By combining a filtering component with an industry standard terminal block, TUSONIX has created an effective barrier to EMI noise. TUSONIX's Filtered Terminal Blocks allow the engineer to eliminate EMI using an existing mechanical design concept.

TUSONIX's commitment to excellence and service allows for customization of the filtered terminal blocks to meet your specific EMC qualifications.

Backed by decades of ceramic component production experience, TUSONIX Filtered Terminal Blocks will meet or exceed your demanding application requirements.

### Benefits

- Saves Labor and Space
- Consistent Panel Layout
- Solves EMI Problems
- Meets Specific Requirements

### Features

- Filter Integral to Block
- Industry Standard Block
- Wide Range of Performance
- Customization

### Catalog Index

Specifications .....	Pg. 2
Pi Circuit Filtered Terminal Blocks ..	Pg. 3
Back Plane Terminal Blocks .....	Pg. 4
C Circuit Filtered Terminal Blocks ..	Pg. 5
Installation Recommendations .....	Pg. 6



### Practical Applications

- Telecommunications
- Computer and Peripheral Equipment
- Industrial Process Control Equipment
- Power Supplies
- Office and Lab Equipment

## Filtered Terminal Block Specifications

### 1.0 Scope

This specification describes the basic performance requirements of TUSONIX Filtered Terminal Blocks.

### 2.0 Capacitance

Measurement Conditions: Capacitance measured at  $25^{\circ}\pm 2^{\circ}\text{C}$ , 50% max R.H. and Frequency of 1 KHz @  $1\pm 0.2\text{VRMS}$ .

### 3.0 Insertion Loss

- 3.1 Measurement Conditions: Insertion Loss values listed are measured in a  $50\Omega$  system at  $25^{\circ}\text{C}\pm 2^{\circ}\text{C}$  under no-load conditions.
- 3.2 Insertion Loss: The Insertion Loss values listed are typical values for both 500 and 600 styles under indicated conditions.
- 3.3 Listed Insertion Loss data is a measurement of filter performance in a matched  $50\Omega$  system. It is highly recommended that filter performance be verified under actual circuit operation conditions.

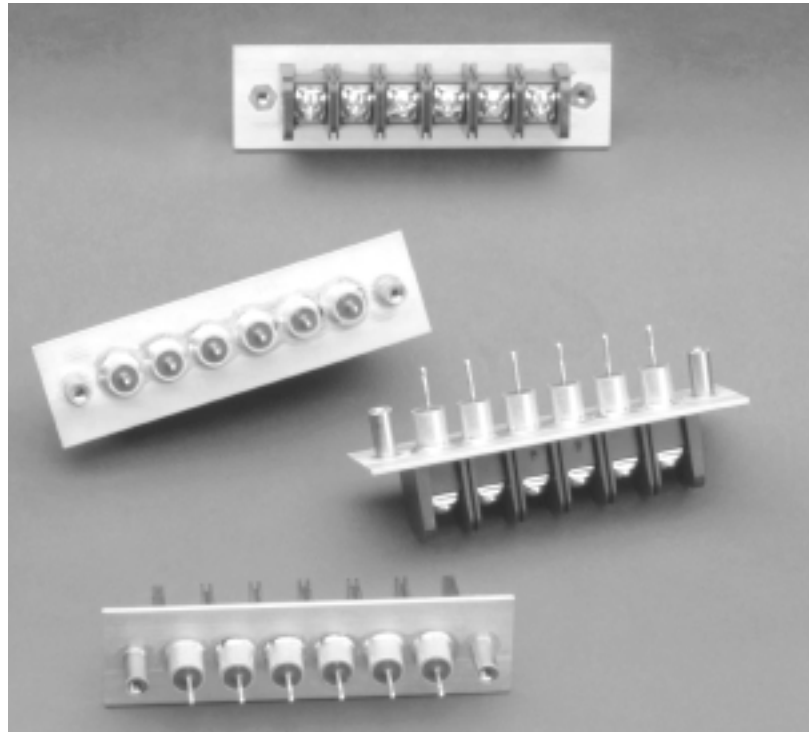

### 4.0 Operating Conditions

Filters are designed to operate continuously at the voltage and current that is stated for each TUSONIX part number. If the operating ambient temperature is significantly higher than  $25^{\circ}\text{C}$ , the terminal blocks should be installed in equipment and tested under actual conditions to ensure that maximum temperatures are not exceeded.

### 5.0 Dielectric Withstanding Voltage

Filters shall withstand the specified voltage applied between the screw terminal and ground plane for one minute. Surge current shall be limited to a maximum of 50mA.

### 6.0 Insulation Resistance

Measured at  $25^{\circ}\text{C}\pm 2^{\circ}\text{C}$  with 100VDC and charging current limited to 50mA max. The IR, after two minutes maximum application of the test voltage, shall be a minimum of 10,000 Megohms.

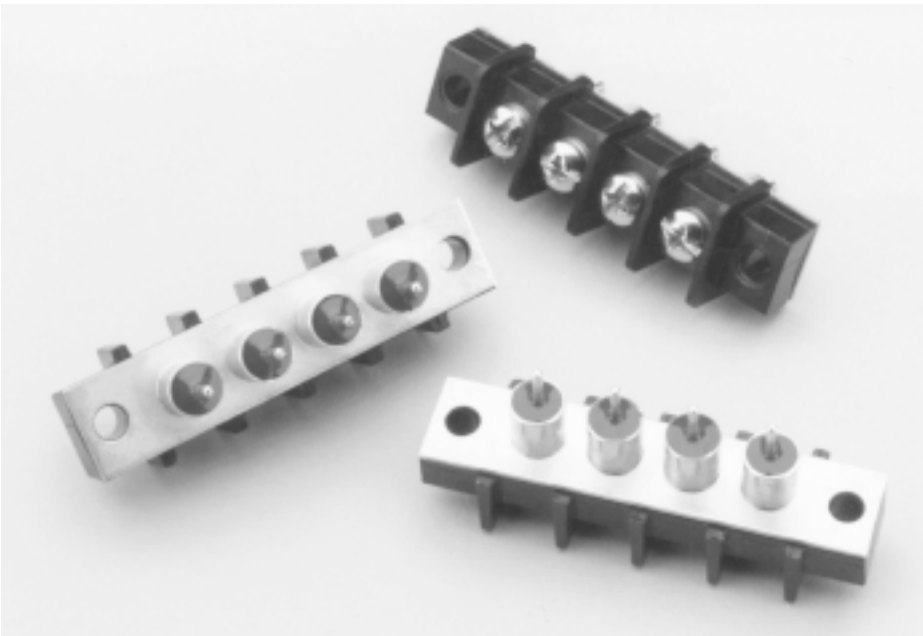

## UL Recognized "Pi" Filtered Terminal Blocks

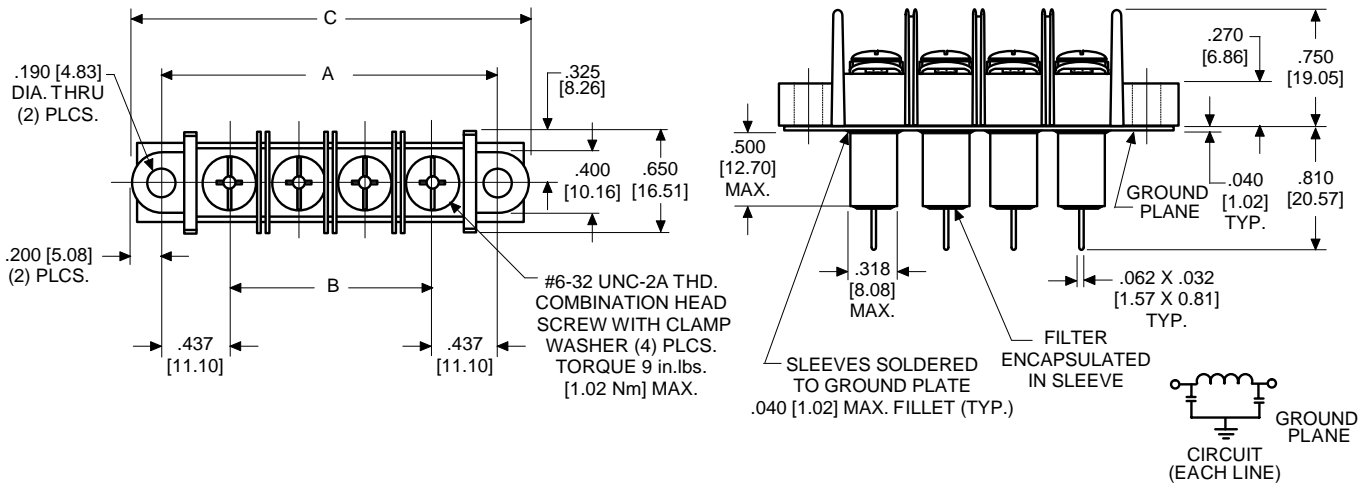

TUSONIX Part Number	Number of Terminals	Screw Size	A		B		C	
7602-501	2	#6-32	1.313	[33.35]	.437	[11.10]	1.710	[43.43]
7603-501	3	#6-32	1.750	[44.45]	.875	[22.23]	2.150	[54.61]
7604-501	4	#6-32	2.188	[55.58]	1.311	[33.30]	2.590	[65.79]
7605-501	5	#6-32	2.625	[66.68]	1.750	[44.45]	3.020	[76.71]
7606-501	6	#6-32	3.063	[77.80]	2.185	[55.50]	3.460	[87.88]
7607-501	7	#6-32	3.500	[88.90]	2.625	[66.68]	3.900	[99.06]
7608-501	8	#6-32	3.938	[100.03]	3.063	[77.80]	4.340	[110.24]
7609-501	9	#6-32	4.375	[111.13]	3.500	[88.90]	4.770	[121.16]
7610-501	10	#6-32	4.813	[122.25]	3.938	[100.03]	5.210	[132.33]

### Mechanical Specifications

- Center Spacing: .437 [11.10]
- Wire Size: up to 12AWG, Ø.081[2.06]
- Molded Material: High Temp Thermo-plastic (PBT), UL rated 94 V-0
- Block Mounting: Recommended mounting screw (#8 Pan Head) Torque 5in.lbs. [0.56 Nm] Max.
- Terminal: Brass, Tin-plated

### UL Recognition

- EMI Filters recognized to UL Standard 1283
- Terminal Block recognized to UL Standard 1059
- Reference UL File Number E201344

### Electrical Specifications

- Operating Temperature: -40°C to +105°C
- Working Voltages: ≤250 VAC\*
- Capacitance: ≥2000pF
- Dielectric Withstanding Voltage: 1500 VAC\*
- Insulation Resistance: ≥10 GΩ
- Current Rating: 20A
- DC Resistance: ≤10 mΩ
- Typical Insertion Loss (dB), in 50 Ω Circuit

10 MHz	100 MHz	1 GHz	10 GHz
5dB	50dB	60dB	65dB

(For additional insertion loss values, please contact the factory directly.)

\*AC Frequency 50/60Hz

## UL Recognized "Pi" Back Plane Filtered Terminal Blocks

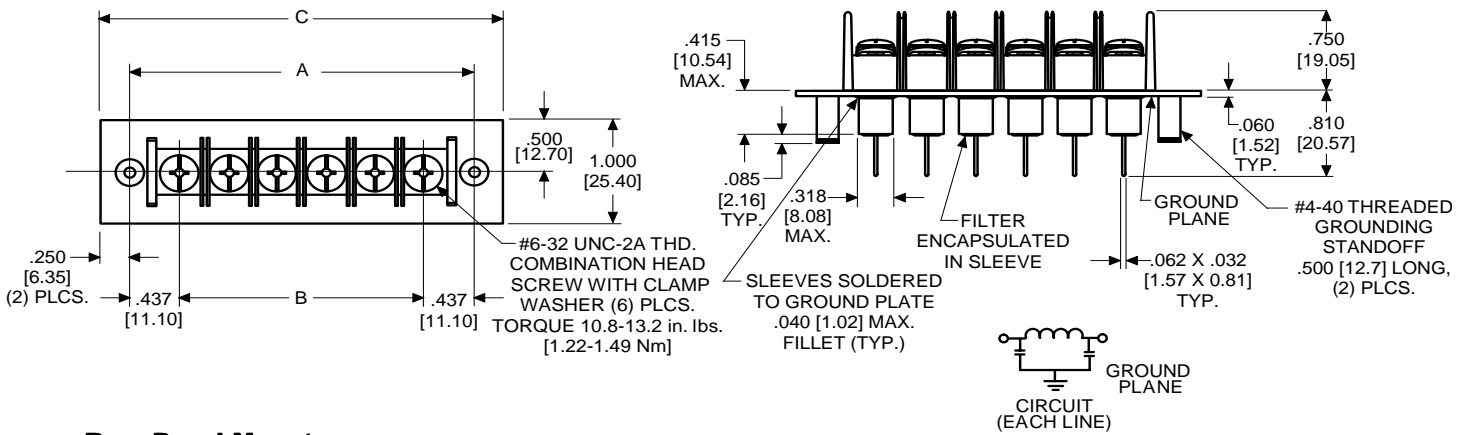

### Rear Panel Mount

TUSONIX Part Number	Number of Terminals	Screw Size	A		B		C	
7602-551	2	#6-32	1.311	[33.30]	.437	[11.10]	1.811	[46.00]
7603-551	3	#6-32	1.748	[44.40]	.874	[22.20]	2.248	[57.10]
7604-551	4	#6-32	2.185	[55.50]	1.311	[33.30]	2.685	[68.20]
7605-551	5	#6-32	2.622	[66.60]	1.748	[44.40]	3.122	[72.30]
7606-551	6	#6-32	3.059	[77.70]	2.185	[55.50]	3.559	[90.40]
7607-551	7	#6-32	3.496	[88.80]	2.622	[66.60]	3.996	[101.50]
7608-551	8	#6-32	3.933	[99.90]	3.059	[77.70]	4.433	[112.60]
7609-551	9	#6-32	4.370	[110.10]	3.496	[88.80]	4.870	[123.70]
7610-551	10	#6-32	4.807	[122.10]	3.933	[99.90]	5.307	[134.80]

### Mechanical Specifications

- Center Spacing: .437 [11.10]
- Wire Size: up to 12AWG,  $\varnothing$ .081[2.06]
- Molded Material: High Temp Thermoplastic (PBT), UL rated 94 V-0
- Terminal: Brass, Tin-plated

### Electrical Specifications

- Operating Temperature:  $-40^{\circ}\text{C}$  to  $+105^{\circ}\text{C}$
- Working Voltages:  $\leq 100$  VDC
- Capacitance:  $\geq 2000$  pF
- Dielectric Withstanding Voltage: 2121 VDC
- Insulation Resistance:  $\geq 10$  G $\Omega$
- Current Rating: 20A
- DC Resistance:  $\leq 10$  m $\Omega$
- Typical Insertion Loss (dB), in 50  $\Omega$  Circuit

10 MHz	100 MHz	1 GHz	10 GHz
5dB	50dB	60dB	65dB

(For additional insertion loss values, please contact the factory directly.)

### UL Recognition

- EMI Filters recognized to UL Standard 1283
- Terminal Block recognized to UL Standard 1059
- Reference UL File Number E201344

## UL Recognized 30 AMP "C" Filtered Terminal Blocks

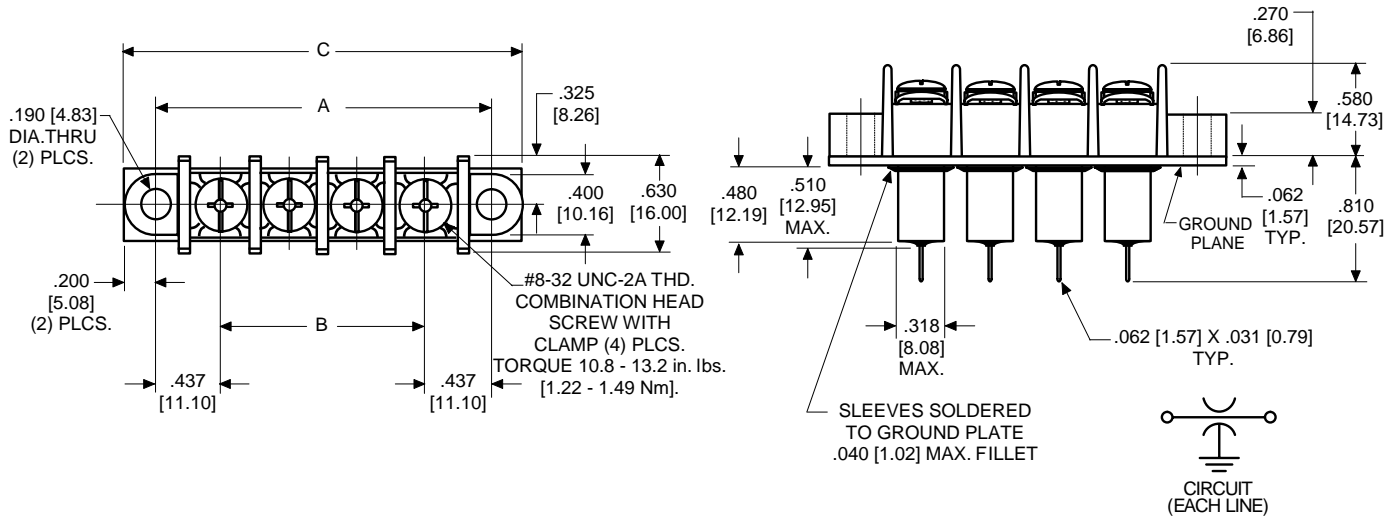

TUSONIX Part Number	Number of Terminals	Screw Size	A		B		C	
		602						
7602-602	2	#8-32	1.311	[33.30]	.437	[11.10]	1.711	[43.46]
7603-602	3	#8-32	1.748	[44.40]	.874	[22.20]	2.148	[54.56]
7604-602	4	#8-32	2.185	[55.50]	1.311	[33.30]	2.585	[65.66]
7605-602	5	#8-32	2.622	[66.60]	1.748	[44.40]	3.022	[76.76]
7606-602	6	#8-32	3.059	[77.70]	2.185	[55.50]	3.459	[87.86]
7607-602	7	#8-32	3.496	[88.80]	2.622	[66.60]	3.896	[98.96]
7608-602	8	#8-32	3.933	[99.90]	3.059	[77.70]	4.333	[110.06]
7609-602	9	#8-32	4.370	[110.10]	3.496	[88.80]	4.770	[121.16]
7610-602	10	#8-32	4.807	[122.10]	3.933	[99.90]	5.207	[132.26]

### Mechanical Specifications

- Center Spacing: .437 [11.10]
- Wire Size: up to 10AWG,  $\varnothing$ .102 [2.59]
- Molded Material: High Temp Thermoplastic (PBT), UL rated 94 V-0.
- Block Mounting: Recommended mounting screw (#8 Pan Head) Torque 5in.lbs. [0.56 Nm] Max
- Terminal: Brass, Tin-plated

### UL Recognition

- EMI Filters recognized to UL Standard 1283
- Terminal Block recognized to UL Standard 1059
- Reference UL File Number E201344

### Electrical Specifications

- Operating Temperature: -40°C to +105°C
- Working Voltages:  $\leq$ 150 VDC
- Capacitance:  $\geq$ 15,000pF
- Dielectric Withstanding Voltage: 2121VDC
- Insulation Resistance:  $\geq$ 10 G $\Omega$
- Current Rating:  $\leq$ 30A (30A rating requires 10 AWG wire and lugs)
- DC Resistance:  $\leq$ 10 m $\Omega$
- Typical Insertion Loss (dB), in 50  $\Omega$  Circuit:

10 MHz	100 MHz	1 GHz	10 GHz
28dB	45dB	70dB	70dB

(For additional Insertion loss values, contact the factory.)

## Product Installation Recommendations

The components in this catalog are manufactured with ceramic dielectrics. To minimize possible damage to the components during installation, the recommendations below should be followed. For information concerning other installation requirements and/or component modifications, consult TUSONIX Customer Engineering at (520) 744-0400.

### General Recommendations

- Handling:** Excessive force or direct impact to the component may result in breakage. Lead bending or cutting, if necessary, should be done with a support for the lead to prevent mechanical stress to the component. Components with required lead modifications are available from TUSONIX.
- Lead Soldering:** Use a temperature controlled soldering iron with SN60, SN63 or low melting point SnAgCu alloy RMA Flux core wire. Maximum soldering temperature to be 500°F(260°C) with a dwell time of 3 seconds maximum. The use of a heat sink between the component body and the solder joint is highly recommended.
- Flux Removal:** Optimum flux removal can be achieved by vapor degreasing the components immediately after the soldering operation. Total immersion of the components is not recommended.

## TUSONIX on-line [www.tusonix.com](http://www.tusonix.com)



The TUSONIX Web site provides visitors with a wide range of product and ordering information.

At [www.tusonix.com](http://www.tusonix.com), customers can download catalogs & part data sheets, check stock and use the cross reference feature, as well as view or link to Sales Offices, International Agents and Distributors.

An on-line request form allows customers to immediately specify product requirements and request additional product information on the spot.